

Model: G1

LASCAM

Gpak G1



Hire Equipment for Logistic Solutions

Gpak G1

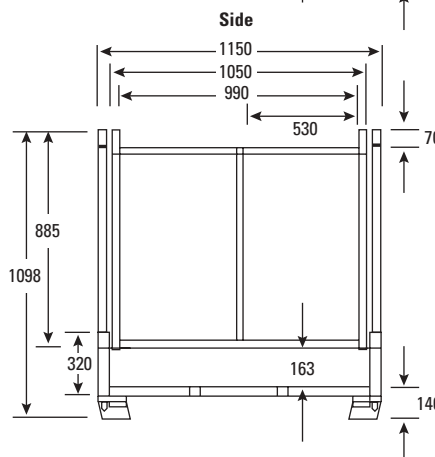
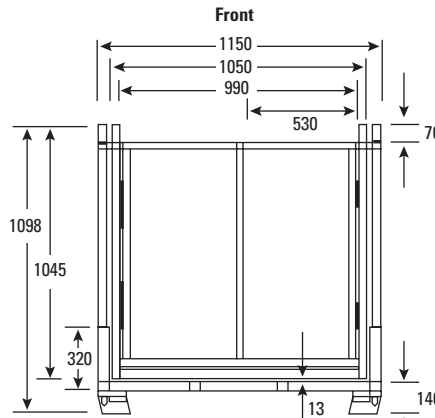
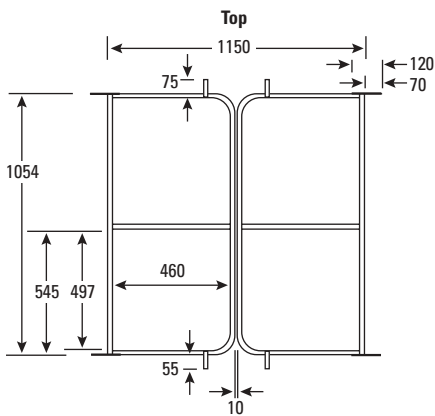

Benefits of Loscam

We can provide you with:

- > The very latest in returnable packaging systems
- > Specialised products and business solutions to assist your equipment management systems in tracking movements through your supply chains
- > Committed to providing customers with the right service at the right time and for the right price

Product	Gpak G1
Overall Size Erect	1150mmL x 1150mmW x 1200mmH
Overall Height Collapsed	410mm
Tare Weight	100kg
Gross Weight	1.10m ³ /1500kg
Construction Material	High tensile galvanised steel Smooth internal plastic lining
Material/Construction Characteristics	Lightweight Stackable for storage
Forklift Access	4 way entry points
Uses	Storage, transport and distribution of products that require special care or are just difficult to handle From the automotive, pharmaceutical, fashion and aquaculture to electronic and transportation industries, Gpak's can reduce transport and handling, theft and product replacement costs
Benefits	Folded to upright in 50 seconds, collapsed in less than 30 seconds Erected by a single person without using tools One-piece foldable units with lids attached Modular design Ergonomic Barcoding EAN 128 compatible Walk in door, no drop gate to bend over Security due to no visual of product inside Stackable/foldable

LOSCAM

Head Office

37 - 41 Prospect Street
Box Hill Victoria 3128
Telephone: 61 3 9843 3700
Facsimile: 61 3 9843 3701
Email: customer.service@loscam.com

State Office details:

New South Wales
Wetherill Park
Telephone: 61 2 9756 3911
Facsimile: 61 2 9756 3955

Queensland
Rocklea
Telephone: 61 7 3277 9166
Facsimile: 61 7 3274 1404

South Australia
Wingfield
Telephone: 61 8 8243 0300
Facsimile: 61 8 8243 0099

Victoria/Tasmania
Hampton Park
Telephone: 61 3 9794 9898
Facsimile: 61 3 9794 0158
Laverton
Telephone: 61 3 9314 3811
Facsimile: 61 3 9314 3822

Western Australia
Canningvale
Telephone: 61 8 9455 6000
Facsimile: 61 8 9455 6222