

LOSCAM

Your Pooling Solutions Partner

Loscam GPAK G3



Product code: G3



www.loscam.com



NZ Customer Service: 0800 Loscam (567226)

Loscam GPAK G3

Loscam G3s are ideal for the movement of bulky and odd-sized freight, where a safe and secure environment is required. Designed to maximise intermodal cubic utilisation, these units are tough, easy to assemble and collapsible. GPAKs ensure occupational health and safety compliance with walk-in doorways to limit bending or stepping over gates.

Benefits:

- Folded to upright in 50 seconds, collapsed in less than 30 seconds
- Erected by a single person without using tools
- One-piece foldable units with attached lids
- Modular design
- Ergonomic
- Walk-in door, mitigates leaning over drop gate
- Increased security, products inside units are not visible
- Reduce theft and products replacement costs
- Stackable/ foldable
- Can be enabled with a Loscam Track & Trace locational device, connected to the Loscam Live tracking platform

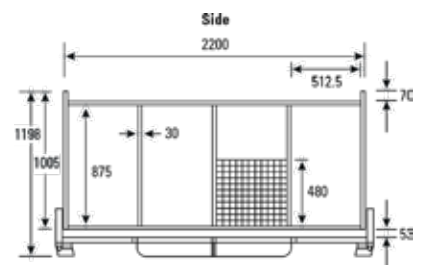
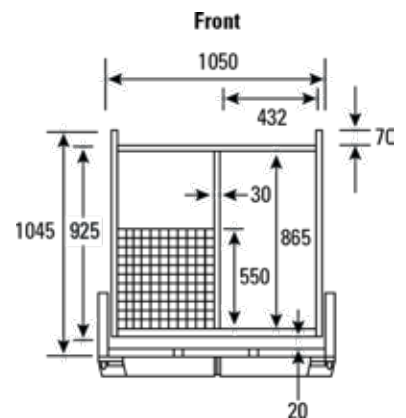

Specifications:

Overall Size:	Erected - 2300 mm(L) x 1150 mm(W) x 1200 mm(H) Collapsed - 2300 mm(L) x 1150 mm(W) x 390 mm(H)
Tare Weight:	160 kg
Gross Weight:	2.31 m ³ / 1,500 kg
Material / Construction Characteristics	<ul style="list-style-type: none">• High tensile galvanised steel• Smooth internal plastic lining• Lightweight• Stackable for storage
Forklift Access:	4-way entry
Uses:	<ul style="list-style-type: none">• Storage, transport and distribution of products that require special care or difficult to handle• Applicable for automotive, pharmaceutical, fashion, agriculture, electronic and transportation industries

LOSCAM

New Zealand
12 Chonny Crescent
Manurewa, Auckland 2102
Ph: 09 269 0566
Fax: 09 622 3090