

# LOSCAM

*Your Pooling Solutions Partner*

## Loscam GPAK G3



Product code: G3



[www.loscam.com](http://www.loscam.com)



**NZ Customer Service: 0800 Loscam (567226)**

# Loscam GPAK G3

Loscam G3s are ideal for the movement of bulky and odd-sized freight, where a safe and secure environment is required. Designed to maximise intermodal cubic utilisation, these units are tough, easy to assemble and collapsible. GPAKs ensure occupational health and safety compliance with walk-in doorways to limit bending or stepping over gates.

## Benefits:

- Folded to upright in 50 seconds, collapsed in less than 30 seconds
- Erected by a single person without using tools
- One-piece foldable units with attached lids
- Modular design
- Ergonomic
- Walk-in door, mitigates leaning over drop gate
- Increased security, products inside units are not visible
- Reduce theft and products replacement costs
- Stackable/ foldable
- Can be enabled with a Loscam Track & Trace locational device, connected to the Loscam Live tracking platform

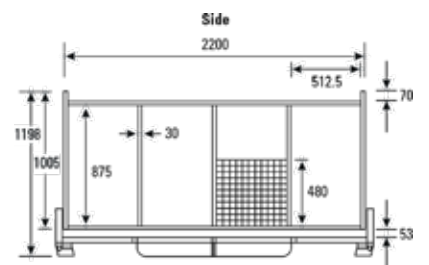
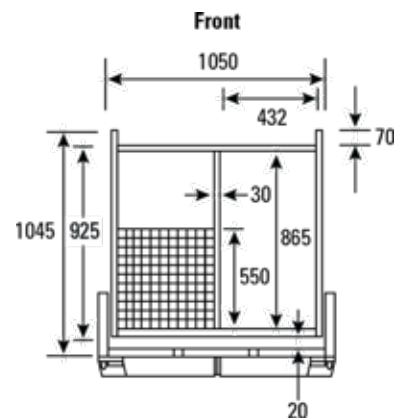

## Specifications:

Overall Size: Erected - 2300 mm(L) x 1150 mm(W) x 1200 mm(H)  
Collapsed - 2300 mm(L) x 1150 mm(W) x 390 mm(H)

Tare Weight: 160 kg

Gross Weight: 2.31 m<sup>3</sup> / 1,500 kg

Material / Construction Characteristics

- High tensile galvanised steel
- Smooth internal plastic lining
- Lightweight
- Stackable for storage

Forklift Access: 4-way entry

Uses:

- Storage, transport and distribution of products that require special care or difficult to handle
- Applicable for automotive, pharmaceutical, fashion, agriculture, electronic and transportation industries

Copyright © LOSCAM. All Right Reserved.  
© Loscam International Holdings Co., Limited

# LOSCAM

**New Zealand**  
12 Chonny Crescent  
Manurewa, Auckland 2102  
Ph: 09 269 0566  
Fax: 09 622 3090