

LOSCAM

Your Pooling Solutions Partner

Loscam IBC I8



Product code: I8



www.loscam.com



AUS Customer Service: 1300 309 930

Loscam IBC I8

The Loscam Foldable Plastic Liquid Intermediate Bulk Container (IBC) - I8 is developed specially for the food industry such as fruit juice, dairy, vegetable oil etc. The lightweight and foldable container features a hygienic efficient "bag in box" system which is easy to fill, discharge and transport. The half folding front "drop gate" enables ease of access and the sight glass provides clear view of the product. I8 is extremely cost-effective for its 2.5 to 1 return ratio.

Benefits:

- Easy to fill, discharge and transport
- Half folding front "drop gate" allows ease of access
- Sight glass provides clear view of product level
- Tamper evident and lockable lid assures product safety
- Freezer compatible and UV resistant
- 2.5:1 folding ratio saves cost in transport and storage
- Can be enabled with a Loscam Track & Trace locational device, connected to the Loscam Live tracking platform

Specifications:

Overall Size:	External - 1155 mm(L) x 1155 mm(W) x 1132 mm(H) Internal - 1065 mm(L) x 1045 mm(W) x 940 mm(H)
Tare Weight:	90 kg
Capacity:	1,060 litre
Loading Capacity:	1,400 kg
Stacking Capacity:	<ul style="list-style-type: none"> • Static- 5 high when loaded, 10 high when folded • Dynamic- 2 high when loaded
Material:	Food-grade Polypropylene
Forklift Access:	4-way entry
Uses:	Suitable for food industry including fruit juices, dairy, fats, oils, honey & syrups, mayonnaise, wine, vinegar and the pharmaceutical industry

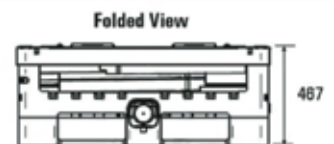
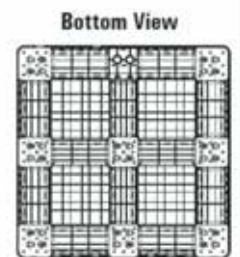
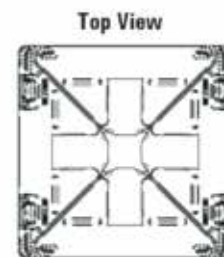
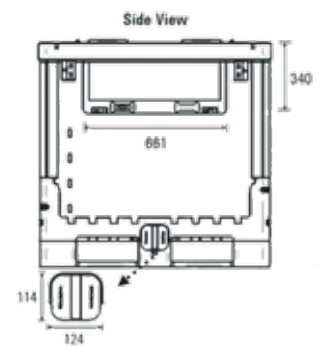
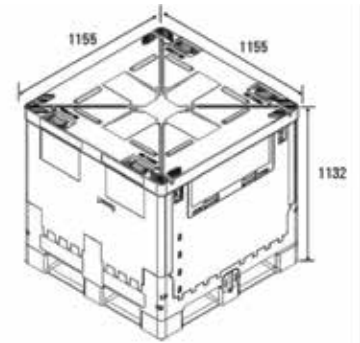

Copyright © LOSCAM. All Right Reserved.
© Loscam International Holdings Co., Limited

LOSCAM

Australia

Level 1, 350
Wellington Road,
Mulgrave 3170
Ph: 61 3 9843 3700
Fax: 61 3 9843 3701

Victoria / Tasmania

51-65 Nathan Rd
Dandenong South
Victoria 3175
Ph: 61 3 9 794 9898
Fax: 61 3 9794 0158

New South Wales

54 Tyrone Place
Erskine Park
NSW 2759
Ph: 61 2 8047 9510
Fax: 61 2 8047 9506

Queensland

55 Whitelaw place
Richlands
QLD-4077
Ph: 61 7 3718 0100
Fax: 61 7 3718 0120

South Australia

196-214 Cormack Rd
Wingfield
SA 5013
Ph: 61 8 8243 0300
Fax: 61 8 8243 0099

Western Australia

280 Bannister Rd
Canning Vale
WA 6155
Ph: 61 8 6103 6000
Fax: 61 8 9455 6222