

LOSCAM

Your Pooling Solutions Partner

Loscam GPAK G1



Product code: G1



www.loscam.com



NZ Customer Service: 0800 Loscam (567226)

Loscam GPAK G1

Loscam G1s are ideal for the movement and storage of high-value products, and at the same time, they are designed to maximise cubic utilisation of all modes of transport. Their easy-to-assemble one-piece construction maximises productivity in picking operations and allows for maximum vehicle utilisation on the reverse logistics leg.

Benefits:

- Folded to upright in 50 seconds, collapsed in less than 30 seconds
- Erected by a single person without using tools
- One-piece foldable units with attached lids
- Modular design
- Ergonomic
- Walk-in door, mitigates leaning over drop gate
- Increased security, products inside units are not visible
- Reduce theft and products replacement costs
- Stackable/ foldable
- Can be enabled with a Loscam Track & Trace locational device, connected to the Loscam Live tracking platform

Specifications:

Overall Size:	Erected - 1150 mm(L) x 1150 mm(W) x 1200 mm(H) Collapsed - 1150 mm(L) x 1150 mm(W) x 410 mm(H)
Tare Weight:	100 kg
Gross Weight:	1.10 m ³ / 1,500 kg
Material Characteristics:	<ul style="list-style-type: none"> • High tensile galvanised steel • Smooth internal plastic lining • Lightweight • Stackable for storage
Forklift Access:	4-way entry
Uses:	<ul style="list-style-type: none"> • Storage, transport and distribution of products that require special care or difficult to handle • Applicable for automotive, pharmaceutical, fashion, agriculture, electronic and transportation industries

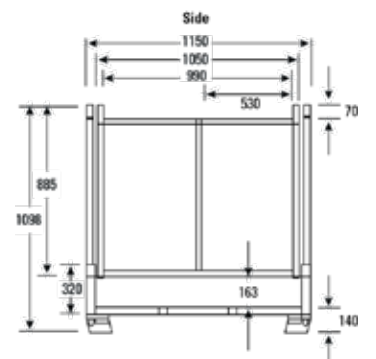
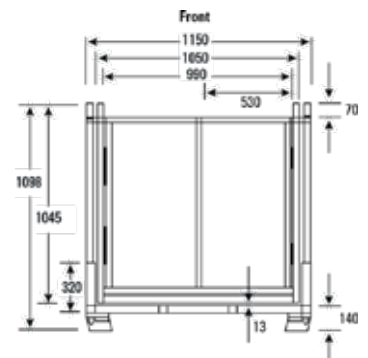
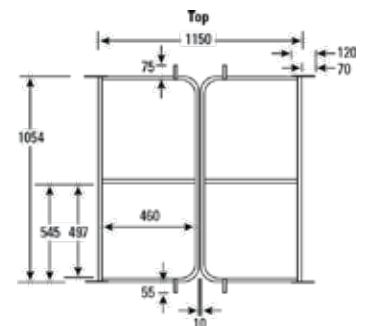

Copyright © LOSCAM. All Right Reserved.
© Loscam International Holdings Co., Limited

LOSCAM

New Zealand
12 Chonny Crescent
Manurewa, Auckland 2102
Ph: 09 269 0566
Fax: 09 622 3090