

# LOSCAM

*Your Pooling Solutions Partner*

## Loscam Collars and Lids



Product code: CS CL



[www.loscam.com](http://www.loscam.com)



AUS Customer Service: 1300 309 930

# Loscam Collars and Lids

Loscam Collars and Lids are an innovative way of transforming pallets into containers for the movement of fragile or cartonised freight without the need for costly shrinkwrap. Easily added to a Loscam wooden pallet, they can be built up to any specification using a combination of collars and lids to create shelves within the unit. They support top loading and are completely collapsible to minimise the cost of reverse logistics.

## Benefits:

- Turns a pallet into containers by directly attaching collars on a standard wooden pallet
- Eliminates cartons and shrinkwrap
- Reduce the risk of manual handling injury
- Collars can be built up around product size and are strong enough to support top loading
- Lateral partitions separate products, minimise crushing and ensure security of valuable products
- Collapsability minimises storage and transport costs, quick to re-engage

## Specifications:

Overall Size Erect:	1155 mm(L) x 193 mm(W) x 220 mm(H) Pallet-Collar Lid & Lateral Partition sheet of plywood 1155 mm(L) x 1155 mm(W) x 9 mm(H)
Overall Size Collapsed:	Each side 1105 mm (L) x 193 mm (W) x 76 mm (H)
Tare Weight:	Collar - 9.5kg Lid - 5 kg
Gross Weight:	Stackable to carry up to 6,000 kg side bearing load
Construction Material:	Kiln-dried dressed pine timber with bevelled edges
Material/ Construction Characteristics:	<ul style="list-style-type: none"> <li>• Hinges are galvanised pressed metal with a spiral locking pin</li> <li>• 4 x galvanised pressed metal right-angle corner pieces lock the lid over the pallet collars</li> </ul>
Forklift Access:	<ul style="list-style-type: none"> <li>• As per wooden pallet</li> <li>• 2-way entry points</li> </ul>
Uses:	<ul style="list-style-type: none"> <li>• Multiple products per pallet</li> <li>• Flexible configuration to suit your product requirements</li> </ul>

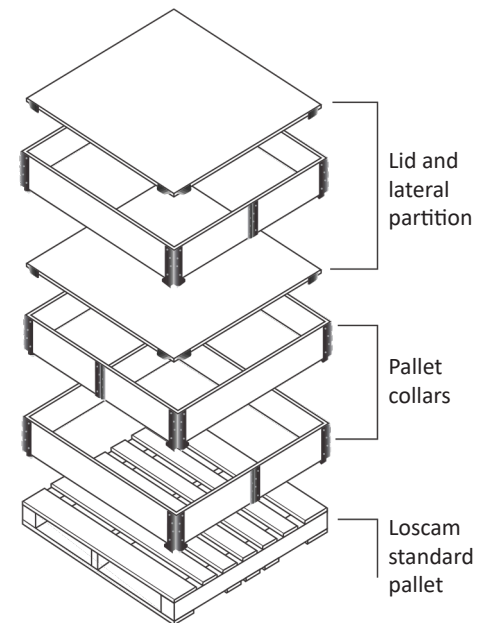
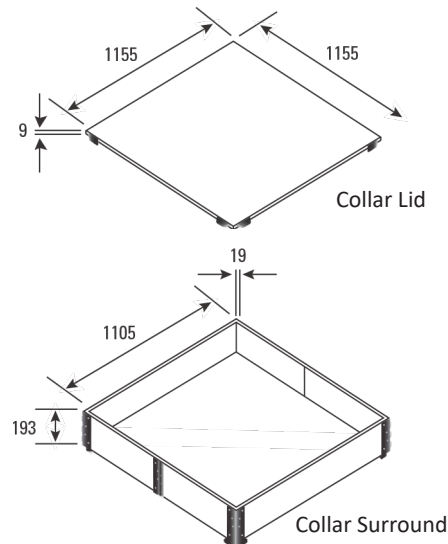

Copyright © LOSCAM. All Right Reserved.  
© Loscam International Holdings Co., Limited

# LOSCAM

**Australia**  
Level 1, 350  
Wellington Road,  
Mulgrave 3170  
Ph: 61 3 9843 3700

**Victoria / Tasmania**  
51-65 Nathan Rd  
Dandenong South  
Victoria 3175  
Ph: 61 3 9 794 9898

**New South Wales**  
54 Tyrone Place  
Erskine Park  
NSW 2759  
Ph: 61 2 8047 9510

**Queensland**  
55 Whitelaw place  
Richlands  
QLD-4077  
Ph: 61 7 3718 0100

**South Australia**  
196-214 Cormack Rd  
Wingfield  
SA 5013  
Ph: 61 8 8243 0300

**Western Australia**  
280 Bannister Rd  
Canning Vale  
WA 6155  
Ph: 61 8 6103 6000