

LOSCAM

Your Pooling Solutions Partner

Loscam GPAK G3



Product code: G3



www.loscam.com



AUS Customer Service: 1300 309 930

Loscam GPAK G3

Loscam G3s are ideal for the movement of bulky and odd-sized freight, where a safe and secure environment is required. Designed to maximise intermodal cubic utilisation, these units are tough, easy to assemble and collapsible. GPAKs ensure occupational health and safety compliance with walk-in doorways to limit bending or stepping over gates.

Benefits:

- Folded to upright in 50 seconds, collapsed in less than 30 seconds
- Erected by a single person without using tools
- One-piece foldable units with attached lids
- Modular design
- Ergonomic
- Walk-in door, mitigates leaning over drop gate
- Increased security, products inside units are not visible
- Reduce theft and products replacement costs
- Stackable/ foldable
- Can be enabled with a Loscam Track & Trace locational device, connected to the Loscam Live tracking platform

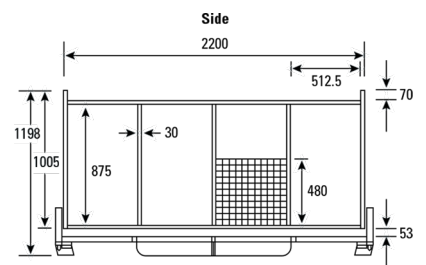
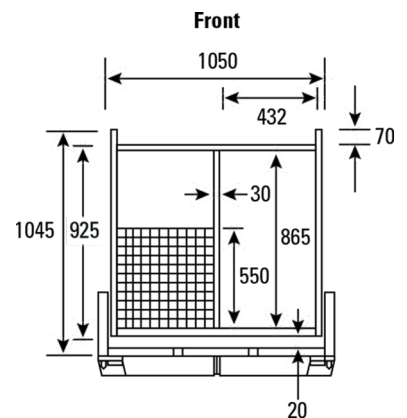

Specifications:

Overall Size: Erected - 2300 mm(L) x 1150 mm(W) x 1200 mm(H)
Collapsed - 2300 mm(L) x 1150 mm(W) x 390 mm(H)

Tare Weight: 160 kg

Gross Weight: 2.31 m³ / 1,500 kg

Material / Construction Characteristics

- High tensile galvanised steel
- Smooth internal plastic lining
- Lightweight
- Stackable for storage

Forklift Access: 4-way entry

Uses:

- Storage, transport and distribution of products that require special care or difficult to handle
- Applicable for automotive, pharmaceutical, fashion, agriculture, electronic and transportation industries



Copyright © LOSCAM. All Right Reserved.
© Loscam International Holdings Co., Limited

LOSCAM

Australia
Level 1, 350
Wellington Road,
Mulgrave 3170
Ph: 61 3 9843 3700

Victoria / Tasmania
51-65 Nathan Rd
Dandenong South
Victoria 3175
Ph: 61 3 9 794 9898

New South Wales
54 Tyrone Place
Erskine Park
NSW 2759
Ph: 61 2 8047 9510

Queensland
55 Whitelaw place
Richlands
QLD-4077
Ph: 61 7 3718 0100

South Australia
196-214 Cormack Rd
Wingfield
SA 5013
Ph: 61 8 8243 0300

Western Australia
280 Bannister Rd
Canning Vale
WA 6155
Ph: 61 8 6103 6000