

LOSCAM

Your Pooling Solutions Partner

Loscam GPAK G5



Product code: G5



www.loscam.com



AUS Customer Service: 1300 309 930

Loscam GPAK G5

Loscam G5s provide the ideal solution for hanging garment distribution and freight that poses height and length challenges. High-value products are protected by the unique locking system in addition to zero visibility of the contents inside the assembled unit. GPAKs are ideal for converting difficult-to-ship freight into optimal shipping units.

Benefits:

- Folded to upright in 50 seconds, collapsed in less than 30 seconds
- Erected by a single person without using tools
- One-piece foldable units with attached lids
- Modular design
- Ergonomic
- Walk-in door, mitigates leaning over drop gate
- Increased security, products inside units are not visible
- Reduce theft and products replacement costs
- Stackable/ foldable
- Can be enabled with a Loscam Track & Trace locational device, connected to the Loscam Live tracking platform

Specifications:

Overall Size:	Erected - 2300 mm(L) x 1150 mm(W) x 2000 mm(H) Collapsed - 2300 mm(L) x 1150 mm(W) x 430 mm(H)
Tare Weight:	200 kg
Gross Weight:	4.16 m ³ / 1,500 kg
Material / Construction Characteristics	<ul style="list-style-type: none"> • High tensile galvanised steel • Smooth internal plastic lining • Lightweight • Stackable for storage
Forklift Access:	4-way entry
Uses:	<ul style="list-style-type: none"> • Storage, transport and distribution of products that require special care or difficult to handle • Applicable for automotive, pharmaceutical, fashion, agriculture, electronic and transportation industries

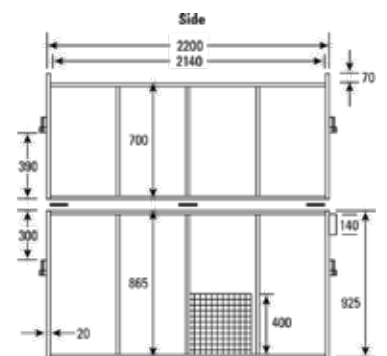
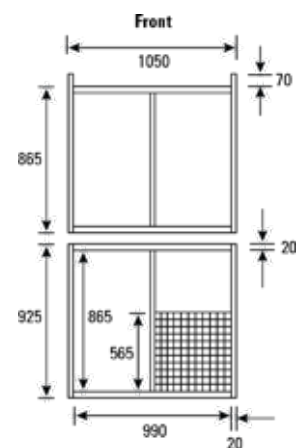

Copyright © LOSCAM. All Right Reserved.
© Loscam International Holdings Co., Limited

LOSCAM

Australia

Level 1, 350
Wellington Road,
Mulgrave 3170
Ph: 61 3 9843 3700
Fax: 61 3 9843 3701

Victoria / Tasmania

51-65 Nathan Rd
Dandenong South
Victoria 3175
Ph: 61 3 9 794 9898
Fax: 61 3 9794 0158

New South Wales

54 Tyrone Place
Erskine Park
NSW 2759
Ph: 61 2 8047 9510
Fax: 61 2 8047 9506

Queensland

55 Whitelaw place
Richlands
QLD-4077
Ph: 61 7 3718 0100
Fax: 61 7 3718 0120

South Australia

196-214 Cormack Rd
Wingfield
SA 5013
Ph: 61 8 8243 0300
Fax: 61 8 8243 0099

Western Australia

280 Bannister Rd
Canning Vale
WA 6155
Ph: 61 8 6103 6000
Fax: 61 8 9455 6222