

LOSCAM

Your Pooling Solutions Partner

Loscam Wooden Pallet - Myanmar



Model: WP15



www.loscam.com

Loscam Wooden Pallet - Myanmar

Benefits of Loscam

- Loscam pallets are available when and where you need them
- ECR approved design- industry standard for retail pallet pooling
- Pallet Hire Management System (HMS) enables customers to track pallets movement between trading partners

Specifications:

Overall Size: 1200 mm(L) x 1000 mm(W) x 156 mm(H)

Tare Weight: 28 kg*

Dynamic Load: 1.5 t

Static Load: 6 t

Forklift Access:

- 2-way entry points
- Stackable/ rackable

Uses:

- Storage for all types of products
- Movement of products between factories and warehouses
- Transfer of products to retailers
- Ideal for pallet magazines and automated production lines

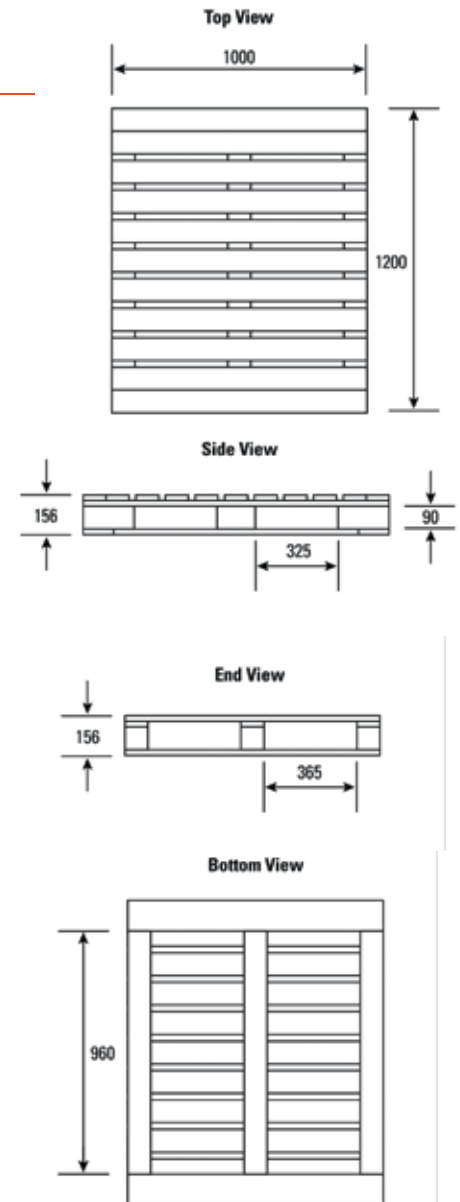

Copyright © LOSCAM. All Right Reserved.
© Loscam International Holdings Co., Limited

LOSCAM

Myanmar

Unit 1116, 11/F, Tower 2
Myanmar Centre Business Suites
No.192 KabaAye Pagoda Road
Bahan Township, Yangon, Myanmar
Ph: 95 1 9345065-68 (Ext 1122)
Fax: 95 1 9345069