

LOSCAM

Your Pooling Solutions Partner

Loscam GPAK G5



Product code: G5



www.loscam.com



NZ Customer Service: 0800 Loscam (567226)

Loscam GPAK G5

Loscam G5s provide the ideal solution for hanging garment distribution and freight that poses height and length challenges. High-value products are protected by the unique locking system in addition to zero visibility of the contents inside the assembled unit. GPAKs are ideal for converting difficult-to-ship freight into optimal shipping units.

Benefits:

- Folded to upright in 50 seconds, collapsed in less than 30 seconds
- Erected by a single person without using tools
- One-piece foldable units with attached lids
- Modular design
- Ergonomic
- Walk-in door, mitigates leaning over drop gate
- Increased security, products inside units are not visible
- Reduce theft and products replacement costs
- Stackable/ foldable
- Can be enabled with a Loscam Track & Trace locational device, connected to the Loscam Live tracking platform

Specifications:

Overall Size:	Erected - 2300 mm(L) x 1150 mm(W) x 2000 mm(H) Collapsed - 2300 mm(L) x 1150 mm(W) x 430 mm(H)
Tare Weight:	200 kg
Gross Weight:	4.16 m ³ / 1,500 kg
Material / Construction Characteristics	<ul style="list-style-type: none">• High tensile galvanised steel• Smooth internal plastic lining• Lightweight• Stackable for storage
Forklift Access:	4-way entry
Uses:	<ul style="list-style-type: none">• Storage, transport and distribution of products that require special care or difficult to handle• Applicable for automotive, pharmaceutical, fashion, agriculture, electronic and transportation industries

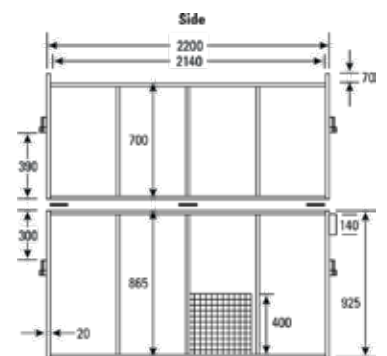
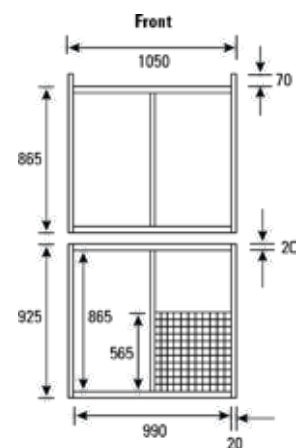

LOSCAM

New Zealand
12 Chonny Crescent
Manurewa, Auckland 2102
Ph: 09 269 0566
Fax: 09 622 3090