

LOSCAM

Your Pooling Solutions Partner

Loscam IBC I8



Product code: I8



www.loscam.com



AUS Customer Service: 1300 309 930

Loscam IBC I8

The Loscam Foldable Plastic Liquid Intermediate Bulk Container (IBC) - I8 is developed specially for the food industry such as fruit juice, dairy, vegetable oil etc. The lightweight and foldable container features a hygienic efficient “bag in box” system which is easy to fill, discharge and transport. The half folding front “drop gate” enables ease of access and the sight glass provides clear view of the product. I8 is extremely cost-effective for its 2.5 to 1 return ratio.

Benefits:

- Easy to fill, discharge and transport
- Half folding front “drop gate” allows ease of access
- Sight glass provides clear view of product level
- Tamper evident and lockable lid assures product safety
- Freezer compatible and UV resistant
- 2.5:1 folding ratio saves cost in transport and storage
- Can be enabled with a Loscam Track & Trace locational device, connected to the Loscam Live tracking platform

Specifications:

Overall Size:	External - 1155 mm(L) x 1155 mm(W) x 1132 mm(H) Internal - 1065 mm(L) x 1045 mm(W) x 940 mm(H)
Tare Weight:	90 kg
Capacity:	1,060 litre
Loading Capacity:	1,400 kg
Stacking Capacity:	<ul style="list-style-type: none"> • Static- 5 high when loaded, 10 high when folded • Dynamic- 2 high when loaded
Material:	Food-grade Polypropylene
Forklift Access:	4-way entry
Uses:	Suitable for food industry including fruit juices, dairy, fats, oils, honey & syrups, mayonnaise, wine, vinegar and the pharmaceutical industry

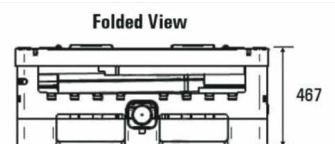
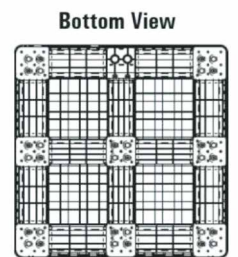
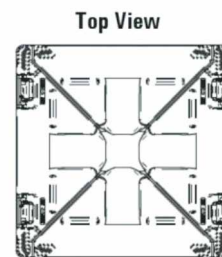
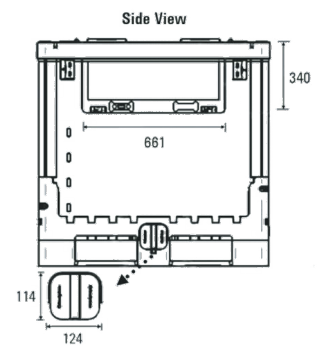
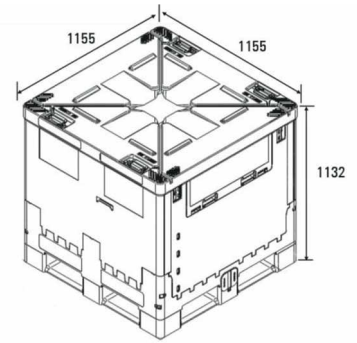

Copyright © LOSCAM. All Right Reserved.
© Loscam International Holdings Co., Limited

LOSCAM

Australia
Level 1, 350
Wellington Road,
Mulgrave 3170
Ph: 61 3 9843 3700

Victoria / Tasmania
51-65 Nathan Rd
Dandenong South
Victoria 3175
Ph: 61 3 9108 3930

New South Wales
54 Tyrone Place
Erskine Park
NSW 2759
Ph: 61 2 8047 9510

Queensland
55 Whitelaw place
Richlands
QLD-4077
Ph: 61 7 3718 0100

South Australia
196-214 Cormack Rd
Wingfield
SA 5013
Ph: 61 8 8472 1401

Western Australia
280 Bannister Rd
Canning Vale
WA 6155
Ph: 61 8 6372 5655