

# LOSCAM

*Your Pooling Solutions Partner*

## Loscam Wooden Pallets - Australia Standard



Product code: WP



[www.loscam.com](http://www.loscam.com)



**AUS Customer Service: 1300 309 930**

# Loscam Wooden Pallet - Australia Standard

The Loscam 'new-gen' radiata pine pallets are made entirely from sustainable pine forests. A sustainable pine forest can produce thousands of new Loscam pallets in just 25 years, compared to 75 years for the same number of hardwood pallets.

## Benefits:

- Manufactured in accordance with AS4068/1993
- 85% of surface coverage
- Able to be used with standard forklift and pallet jack equipment without modification
- Improved transport efficiencies due to lighter weight materials
- Consistent quality and supply
- Repairable - increased lifespan as most damage can be repaired, reducing wastage and costs
- Counter sunk nails in softwood reduces risk of product damage

## Specifications:

Overall Size:	1165 mm (L) x 1165 mm (W) x 150 mm (H)
Tare Weight:	34 kg*
Racking (Drive-in & Standard):	Max 2,000 kg payload
Static Load:	Max 10,000 kg
Construction Material:	Plantation Radiata Pine
Construction Material:	<ul style="list-style-type: none"> <li>• 63 mm wide softwood bearer</li> </ul>
Characteristics:	<ul style="list-style-type: none"> <li>• Softwood bearers tend to dent rather than split when impacted on end</li> <li>• Lighter than hardwood for safer handling</li> </ul>
Forklift Access:	<ul style="list-style-type: none"> <li>• Bottom entry boards – 150 mm x 25 mm</li> <li>• 2-way entry points</li> <li>• Stackable/rackable</li> </ul>
Uses:	<ul style="list-style-type: none"> <li>• Ideal for bagged product as it prevents spooning</li> <li>• Designed for shrink-wrapping facilities</li> <li>• Packaged goods</li> <li>• Automated production facilities and storage environments</li> <li>• Widely accepted across supply chain</li> </ul>

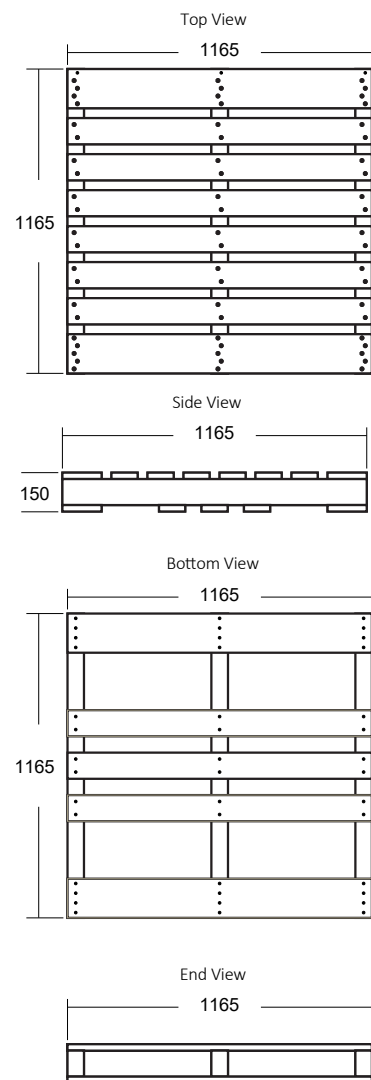

\* Pallet weight is impacted by a number of factors including but not limited to moistures, age, timber, characteristics, etc. As such, Loscam does not warrant the weight of any pallet so provided and that the hirer or user of the pallet shall at all times be responsible on how the pallet(s) are used, stored or handled while under their control. All pallets meet our fit for purpose guidelines as published on the Loscam website: [www.loscam.com](http://www.loscam.com).

# LOSCAM

**Australia**  
Level 1/37-41  
Prospect St Box Hill  
Victoria 3128  
Ph: 61 3 9843 3700  
Fax: 61 3 9843 3701

**Victoria / Tasmania**  
51-65 Nathan Rd  
Dandenong South  
Victoria 3175  
Ph: 61 3 9 794 9898  
Fax: 61 3 9794 0158

**New South Wales**  
54 Tyrone Place  
Erskine Park  
NSW 2759  
Ph: 61 2 8047 9510  
Fax: 61 2 8047 9506

**Queensland**  
55 Whitelaw place  
Richlands  
QLD-4077  
Ph: 61 7 3718 0100  
Fax: 61 7 3718 0120

**South Australia**  
196-214 Cormack Rd  
Wingfield  
SA 5013  
Ph: 61 8 8243 0300  
Fax: 61 8 8243 0099

**Western Australia**  
280 Bannister Rd  
Canning Vale  
WA 6155  
Ph: 61 8 6103 6000  
Fax: 61 8 9455 6222